



Advanced Generation: Fuel Cells for Buildings

Tech Brief

Distributed Energy Resources (DER) are a suite of onsite, grid-connected or stand-alone technology systems that can be integrated into residential, commercial, or institutional buildings and/or industrial facilities. These energy systems include distributed generation, renewable energy, and hybrid generation technologies; energy storage; thermally activated technologies that use recoverable heat for cooling, heating, or power; transmission and delivery mechanisms; control and communication technologies; and demand-side energy management tools. Such decentralized resources offer advantages over conventional grid electricity by offering end users a diversified fuel supply; higher power reliability, quality, and efficiency; lower emissions; and greater flexibility to respond to changing energy needs.

Fuel cells were discovered in 1839, when scientist William Grove accidentally let a hydrolysis experiment run backwards. He was surprised to learn that electron flows were created when hydrogen and oxygen combined. NASA made this technology well known with its use in space shuttles. This clean energy source has captivated the energy world ever since.

Fuel cells consist of two electrodes (cathode and anode) around an electrolyte. The generation process involves introducing hydrogen to one side of the fuel cell (the anode), where it breaks apart into protons and electrons. The electrode conducts protons but not electrons. The protons then flow through while the electrons travel through the external circuit and provide electrical power. The electrons and protons are reunited at the other end of the fuel cell (the cathode). When combined with oxygen from the air, fuel cells produce water and heat in a process that is practically silent, nearly emission-free, and involves no moving parts.

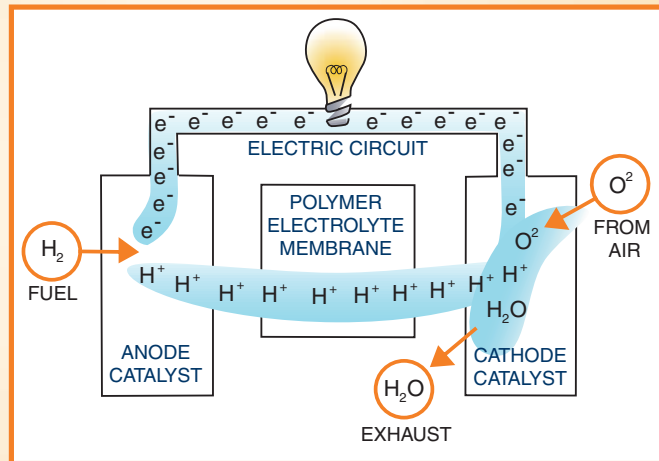

Typical Proton Exchange Membrane Fuel Cell

A fuel cell's "fuel" is hydrogen, which is typically isolated or "reformed" from a hydrocarbon source, such as natural gas, propane, methanol, or even gasoline. The necessary oxygen is extracted from ambient air. Fuel cells have a power range of 30-300 kW and provide a direct current (DC) voltage that can be converted into more useful alternating current (AC) with rectifiers for 24/7 use or

backup generation in building applications.

Fuel cells are categorized by the kind of electrolyte they use. Electrolyte types used in the building sector include phosphoric acid, molten carbonate, solid oxide, and proton exchange membrane (PEM). High-temperature molten carbonate and solid oxide fuel cells are undergoing full-scale

demonstration with some existing applications. PEM fuel cell units show the most versatility and promise of market adoption and are growing in popularity. Manufacturers are actively pursuing this technology for widespread, general use in commercial buildings, homes, and transportation. As of this writing, there were approximately 50 manufacturers of fuel cells in the United States.

Market Potential

- ▶ According to the Business Communications Company, the market for fuel cells was about \$218 million in 2000, will rise to \$2.4 billion by 2004, and reach \$7 billion by 2009.
- ▶ PEM fuel cells can provide reliable power to the "digital economy."
- ▶ Fuel cells position the U.S. fuel cell industry as a leader in this dynamic technology, creating new opportunities for international trade and domestic jobs.

Environmental Benefits

- ▶ Fuel cells generate none of the CO, SO_x, and NO_x associated with fossil fuel combustion.
- ▶ CO₂ emissions are minimal. Using a 50-kW PEM fuel cell instead of a coal-fired plant to generate onsite electricity for a building will offset over 900,000 lbs. of CO₂ in one year.
- ▶ If the carbon were sequestered during the reforming stage, the entire energy system would approach zero pollution.

Applications

The Fuel Cell for Buildings Program will focus initially on a PEM for light commercial buildings—office buildings and health, lodging, and educational facilities. Fuel cells also can provide prime or back-up power for homes. Several manufacturers offer residential sector-scaled fuel cells in the 3- to 10-kW range that can easily power a home or be used to shave or offset expensive peak electricity charges.

Fuel cells may achieve early adoption in the “premium power” industries, such as data centers, clean rooms, computer chip manufacturers, chemical plants, credit card processors, and other high-density electric loads (HiDELS). These industries may be willing to pay higher costs for the reliability that fuel cells offer.



Fuel Cell

Program Activities and Goals

The program's near-term goals are to install a full laboratory prototype PEM fuel cell system in a building in 2004, and develop a commercial product based on the first-generation PEM by 2005.

Another goal is to improve the efficiency of reformers that extract hydrogen from a variety of fuels, including natural gas, propane, and clean oil. DEER plans to initiate testing of a laboratory prototype Natural Gas Fuel Cell Processor with CO clean-up capability for high-temperature, stationary PEM fuel cells.

The design and evaluation of IES that use heat from the fuel cell will be an integral part of the longer term program. Very important is the gain in overall system efficiency when hot water generated by the fuel cell drives a thermally activated heat pump, chiller, or desiccant dehumidification system.

For further information:

Office of Energy Efficiency and Renewable Energy
www.eren.doe.gov

Office of Distributed Energy and Electric Reliability
www.eren.doe.gov/deer.html

Fuel Cells 2000
www.fuelcells.org

Partners:

3M

Argonne National Laboratory

Arthur D. Little

Aspen Systems, Inc.

Catalytica Energy Systems

Caterpillar Inc.

DeNora North America

Fuel Cell Energy

Foster Miller Associates

Gas Technology Institute

General Electric Corporation

Honeywell

Hydrogen Burner Technology

International Fuel Cells

Kse

Pacific Northwest National Laboratory

Pennsylvania State University

Plug Power

Porvair Corporation

Superior MicroPowders

University of Michigan, Ann Arbor

Virginia Polytechnic Institute

Virginia State University

Contact:

Ronald Fiskum
U.S. Department of Energy
1000 Independence Avenue
Washington, DC 20585
Tel: (202) 586-9154
ronald.fiskum@hq.doe.gov



U.S. Department of Energy
Office of Energy Efficiency and Renewable Energy

